

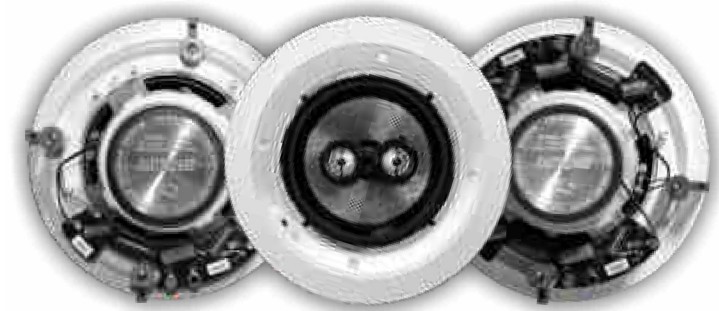

Q
Series
Speakers



6" and 8"
Round In-Ceiling
Single and Dual 8Ω Speakers

User's Manual



Earthquake Sound reserves the right to amend details of the specifications without notice.
Copyright © Earthquake Sound Corporation
Earthquake Sound Corporation • 2727 McCone Avenue Hayward CA, 94545
Phone: 510-732-1000 Fax: 510-732-1095

Congratulations on your choice of IQ Series In-Ceiling Speaker systems, one of Earthquake's most valued in-ceiling speaker lines. With the proper installation and operation, the IQ speakers will provide a lifetime of durability and high-end performance.

It is very important to follow all installation/mounting instructions and recommendations in this manual closely and carefully to insure optimal performance operation and longevity.

Advanced Features:

- Elaborate crossover networks with $\pm 3\text{dB}$ tonal adjustments
- Available in Single and Dual 8Ω voice coils
- High quality capacitors and no distortion steel core inductors
- Easy Turn-N-Lock™ installation mechanisms
- Dual silk NEO swiveling tweeters
- Low mass woven glass fiber woofer cones with extra wide rubber surrounds
- Paintable frames and rust-proof aluminum grilles

Painting Guidelines:

The IQ speakers are paintable and can accept virtually any type of paint. Spray and roller paint applications typically provide the best results. When you are ready to begin painting, remember to shield the driver and tweeter from the paint. Also, be sure to remove the inner grille cloth prior to painting and replace it once the paint has completely dried.

The IQ speakers' aluminum grilles and woven carbon fiber cones makes these speakers the best ones to use in humid areas such as kitchens and bathrooms.

Speaker Placement:

The IQ speakers are designed to be flush mounted in the walls or ceilings. To optimize their acoustics you should follow these simple guidelines:

For best stereo reproduction the speakers should be placed an equal distance from your listening position and separated so that the angle between them is between 40 and sixty degrees. The units should be placed with the tweeters near the ear level of the seated listener.

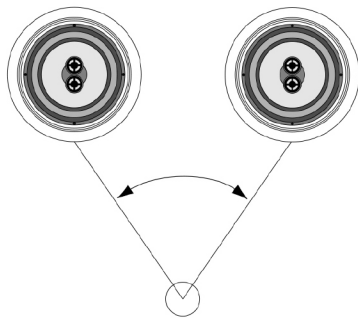
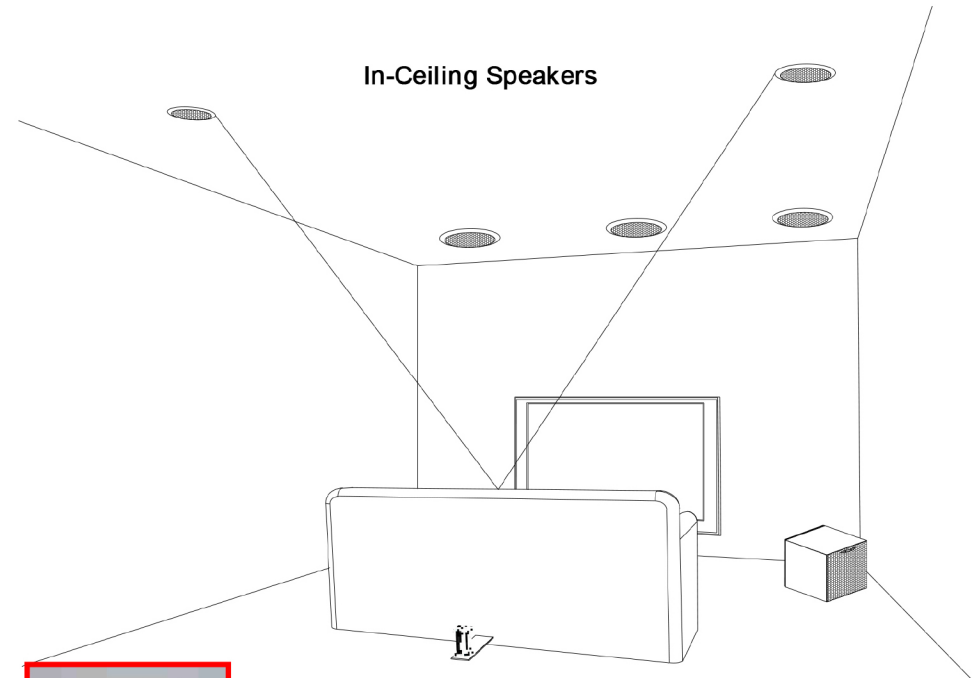

Figure 1



WARNING: These products are capable of generating high sound pressure levels. You should exercise caution when operating these speakers. Long term exposures to high levels of sound pressure will cause permanent damage to your hearing. Sound pressure levels exceeding 85dB can be dangerous with constant exposure, set your audio system to a comfortable loudness level. Earthquake Sound Corporation does not assume liability for damages resulting from the direct use of Earthquake speakers, and urges users to play volume at moderate levels.



1 Cut the hole: using the provided cut out template



2 Wire the speaker: using the non-obtrusive spring-loaded speaker terminals



3 Mount the speaker: by utilizing the Turn-N-Lock™ installation mechanisms

CM-6S SPECIFICATIONS

Frequency Response:	40Hz - 21kHz
Sensitivity:	93dB @ 1W/1M
Nominal Impedance:	Single 8-Ohm
Power Handling:	300 Watts
Enclosure Material / Type:	Infinite baffle, flush with wall
Drive Components:	Two-way system using: dual 20mm silk dome swiveling neodymium tweeters and one 6 ½" low mass woven glass fiber cone woofer
Wire Gauge Recommended:	12
Weight Per Speaker:	2.78 lbs.
Grille Frame Diameter:	9.8" / 250mm
Cut Out Hole Diameter:	8.7" / 221mm
Mounting Depth:	3.3" / 86mm
Finish:	White / Paintable
Rough-in Bracket:	RK-IQ6

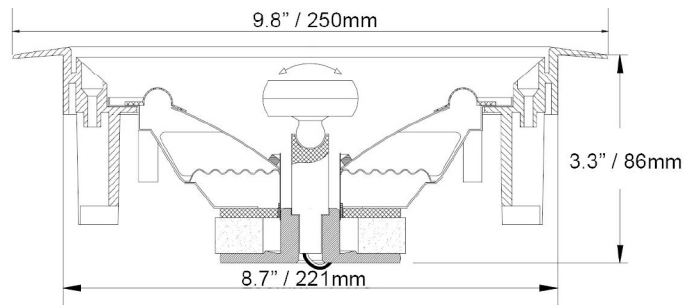

CM-6Dual SPECIFICATIONS

Frequency Response:	40Hz - 21kHz
Sensitivity:	93dB @ 1W/1M
Nominal Impedance:	Dual 8-Ohm
Power Handling:	300 Watts
Enclosure Material / Type:	Infinite baffle, flush with wall
Drive Components:	Two-way system using: dual 20mm silk dome swiveling neodymium tweeters and one 6 ½" low mass woven glass fiber cone woofer
Wire Gauge Recommended:	12
Weight Per Speaker:	3.42 lbs.
Grille Frame Diameter:	10" / 252mm
Cut Out Hole Diameter:	8.7" / 221mm
Mounting Depth:	3.3" / 86mm
Finish:	White / Paintable
Rough-in Bracket:	RK-IQ6

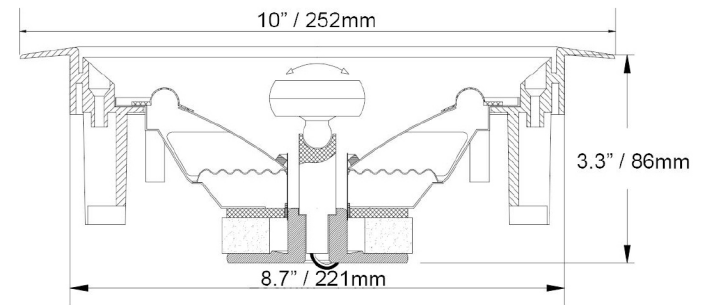

CM-8S SPECIFICATIONS

Frequency Response:	30Hz - 21kHz
Sensitivity:	91dB @ 1W/1M
Nominal Impedance:	Single 8-Ohm
Power Handling:	400 Watts
Enclosure Material / Type:	Infinite baffle, flush with wall
Drive Components:	Two-way system using: dual 20mm silk dome swiveling neodymium tweeters and one 8" low mass woven glass fiber cone woofer
Wire Gauge Recommended:	12
Weight Per Speaker:	4.28 lbs.
Grille Frame Diameter:	11.4" / 292mm
Cut Out Hole Diameter:	9.8" / 251mm
Mounting Depth:	4" / 104mm
Finish:	White / Paintable
Rough-in Bracket:	RK-SS8

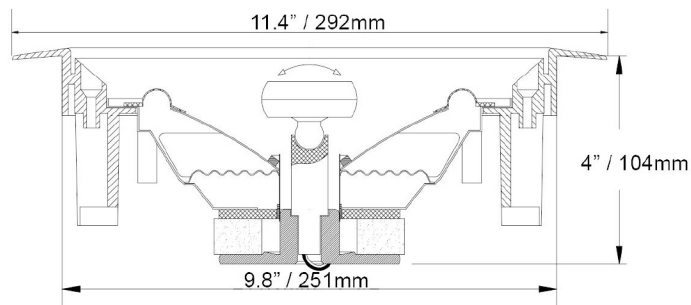

CM-8Dual SPECIFICATIONS

Frequency Response:	30Hz - 21kHz
Sensitivity:	91dB @ 1W/1M
Nominal Impedance:	Dual 8-Ohm
Power Handling:	400 Watts
Enclosure Material / Type:	Infinite baffle, flush with wall
Drive Components:	Two-way system using: dual 20mm silk dome swiveling neodymium tweeters and one 8" low mass woven glass fiber cone woofer
Wire Gauge Recommended:	12
Weight Per Speaker:	4.48 lbs.
Grille Frame Diameter:	11.5" / 294mm
Cut Out Hole Diameter:	9.8" / 251mm
Mounting Depth:	4.2" / 107mm
Finish:	White / Paintable
Rough-in Bracket:	RK-SS8

