

ME-640 PLATEAMP

USER MANUAL

ME-640



**EARTHQUAKE
EARTHQUAKE
SOUND**

Sound That Will Move You.

Earthquake Sound reserves the right to amend the details of the specifications without notice.
© Copyright Earthquake Sound Corporation.

Earthquake Europe • www.earthquakesound.eu • Mogensensvej 29 Dk-5000 Odense C
Office: +45 2043 8007 • support@earthquakesound.dk

Safety Instructions



WARNING

TO REDUCE THE RISK OF FIRE OR ELECTRIC SHOCK, DO NOT EXPOSE THIS APPLIANCE TO RAIN OR MOISTURE. NO USER SERVICEABLE PARTS INSIDE. REFER SERVICING TO QUALIFIED SERVICE PERSONNEL.

- 1. Read Instructions** — All the safety and operation instructions should be read before the Earthquake Component is operated.
- 2. Retain Instructions** — The safety and operating instructions should be kept for future reference.
- 3. Heed Warnings** — All warnings on the Components in these operating instructions should be followed.
- 4. Follow Instructions** — All operating and other instructions should be followed.
- 5. Water and Moisture** — The Component should not be used near water - for example, near a bathtub, washbowl, kitchen sink, laundry tub, in a wet basement, or near a swimming pool, etc.
- 6. Ventilation** — The Component should be situated so that its location or position does not interfere with its proper ventilation. For example, the Component should not be situated on a bed, sofa, rug, or similar surface that may block any ventilation openings; or placed in a built-in installation such as a bookcase or cabinet that may impede the flow of air through ventilation openings.
- 7. Heat** — The Component should be situated away from heat sources such as radiator, or other devices which produce heat.
- 8. Power Sources** — The Component should be connected to a power supply only of the type described in these operation instructions or as marked on the Component.
- 9. Power Cord Protection** — Power-supply cords should be routed so that they are not likely to be walked upon or pinched by items placed upon or against them, paying particular attention to cords at plugs, convenience receptacles, and the point where they exit the Component.
- 10. Cleaning** — The Components should be cleaned only as recommended in this manual.
- 11. Non-use Periods** — The power cord of the Component should be unplugged from the outlet when unused for a long period of time.
- 12. Object and Liquid Entry** — Care should be taken so that objects do not fall into and liquids are not spilled inside of the Component.

13. Damage Requiring Service — The Component should be served only by EQ qualified serviced personnel when:

- a. The power-supply cord or the plug has been damaged; or
- b. Objects have fallen, or liquid has spilled into the Component; or
- c. The Component has been exposed to rain; or
- d. The Component does not appear to operate normally or exhibits a marked change in performance; or
- e. The Component has been dropped, or its cabinet damaged.

14. Servicing — The user should not attempt to service the Component beyond those means described in this operating manual. All other servicing should be referred to qualified Earthquake service personnel.

15. To Prevent Electric Shock — Do not use this polarized plug with an extension cord, receptacles of other outlet unless the blades can be fully inserted to prevent blade exposure.

16. Grounding or Polarization — Precautions should be taken so that the grounding or polarization means of the Component is not defeated.

This apparatus does not exceed the Class A/Class B (which ever is applicable) limits for radio noise emissions from digital apparatus as set out in the radio interference regulations of the Canadian Department of Communications.



The exclamation point within an equilateral triangle is intended to alert the user of the presence of important operating and maintenance (servicing) instructions in the literature accompanying the appliance.



The lightning flash with arrowhead symbol within an equilateral triangle is intended to alert the user to the presence of uninsulated "dangerous voltage" within the product's enclosure, that may be of sufficient magnitude to constitute a risk of electric shock to a person.

Table of Contents

Safety Instructions.....	2
Overview.....	4
Installation.....	6
Connections.....	8
System Configurations.....	9
Adjusting the Controls.....	12
Specifications.....	13



WARNING: The MiniMe subwoofers are capable of generating high sound pressure levels. You should exercise caution when operating these speakers. Long term exposures to high levels of sound pressure will cause permanent damage to your hearing. Sound pressure levels exceeding 85dB can be dangerous with constant exposure, set your audio system to a comfortable loudness level. Earthquake Sound Corporation does not assume liability for damages resulting from the direct use of the MiniMe subwoofers , and urges users to play volume at moderate levels.



Overview - ME-640 Plateamp

Control Panel Overview

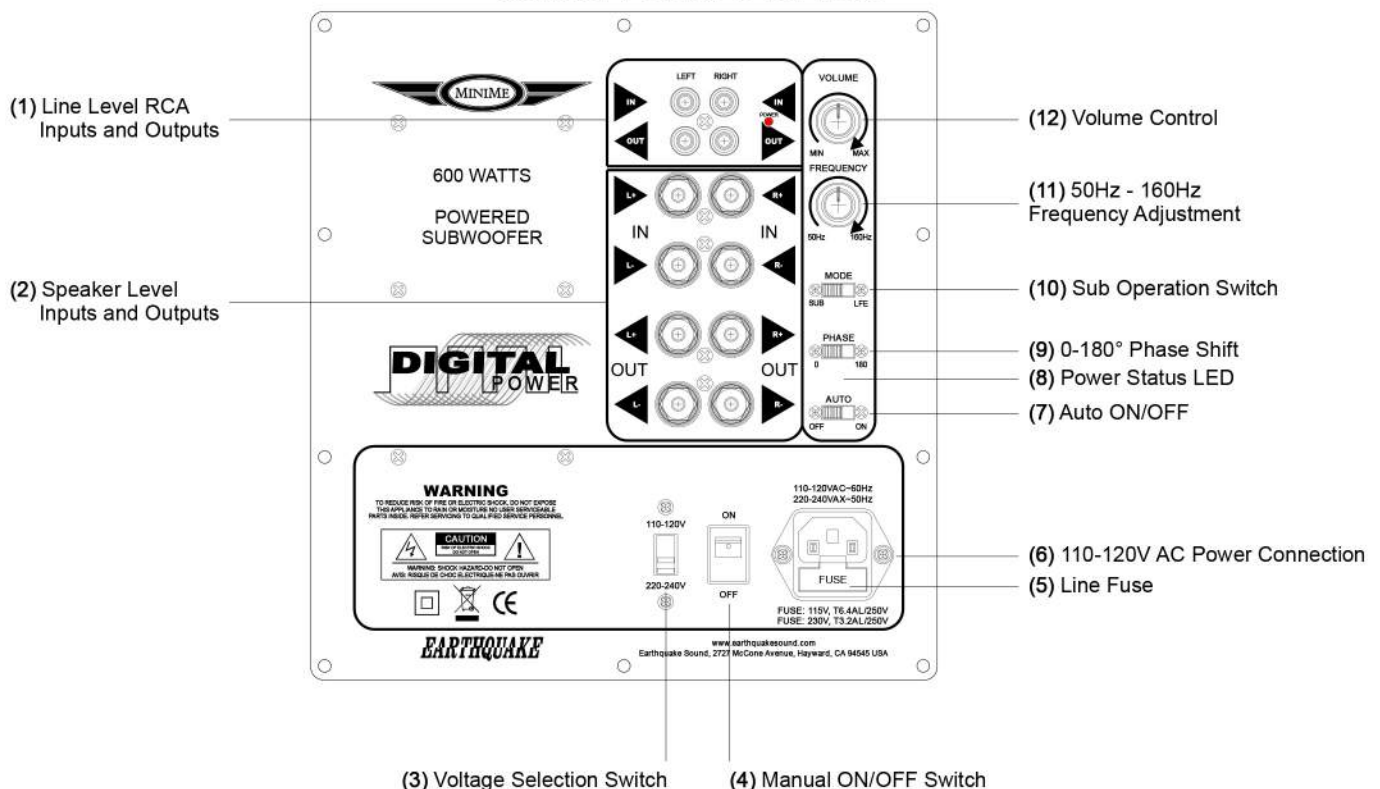

(1) Line Level RCA Inputs

Connect with RCA type patch cords to the line level output of your receiver or pre-amp. If your pre-amplifier or receiver has a single sub/LFE output, connect it to the subwoofer's left input jack. There is no need to use the subwoofers right input jack. If you want to run your main/satellite speakers full range, use a "Y" adapter at the pre-amplifier outputs. In this way, you can send the pre-amplifier's output signal to your main amplifier and to the subwoofer at the same time.

(2) High Level Inputs / Outputs

Under normal conditions, the preferred connection is through the Line Level inputs. If this is difficult or not possible in your system, then you can use the Speaker Level inputs. Also, if you experience excessive noise or hum with the Line Level input, often a simple change to the Speaker Level input will result in a lower background noise level.

Connect the Speaker Level inputs to the speaker-level outputs of your amplifier or receiver using speaker wire. The binding posts can accept bare wire connections only.

High Level: Connecting the Subwoofer using the high level speaker connections: On the rear of your MiniMe Subwoofer are two pairs of red and black binding posts. One set is marked "Input" and one set is marked "Output", with each pair designated as left or right. Each post is color-coded black/red. These

terminals will accept up to 16-gauge quality speaker wire. The Inputs should be connected to the left and right speaker terminals of your amplifier or receiver. The Outputs should run from the subwoofer to the left and right satellite speakers. Remember: Always connect red-to-red and black-to-black, when making connections between an amplifier/receiver to the subwoofer. If you inadvertently reverse one of the connections (i.e., red-to-black), you will notice a lack of bass from your subwoofer.

(3) Voltage Selection Switch

The voltage switch is positioned according to area voltage requirements. It has been pre-set prior to shipping from the factory.

CAUTION

Do not try to alter the voltage setting, as doing so will result in a blown fuse. A wrong setting may result in damaged electronics.

(4) Manual ON/OFF Switch

In the "ON" position, the subwoofer will remain "on" constantly or can turn "on" and "off" automatically when the "AUTO/ON" circuit is engaged. In the "OFF" position, the subwoofer will remain off until the switch is manually turned back to the "ON" position.

(5) Line Fuse

The subwoofer is supplied with a conservative, slow-blow type fuse to protect the electronics.

Overview Continued On Next Page»

Overview - ME-640 Plateamp

(6) Auto ON/OFF

When the main "POWER" ON/OFF switch is in the "OFF" position, this switch has no effect on the subwoofer. When the main "POWER ON/OFF" switch is in the "ON" position, this switch allows the auto circuit to be engaged. When this switch is in the "AUTO" position, the subwoofer will automatically turn "on" when it senses a signal. It will automatically turn "off" after 20 minutes with no signal. When this switch is in the "ON" position, the subwoofer will remain on as long as the "POWER" ON/OFF switch is in the "ON" position.

(7) 110-120V AC Power Connection

The Earthquake MiniMe is equipped with a built in standard, two-prong power connection.

(8) Power Status LED

Earthquake powered subwoofers have an LED on the panel that indicates the status of the built-in amplifier. The LED will light red when the amplifier is in standby mode and green when the amplifier is on and receiving a signal.

(9) 0-180° Phase Shift

This control is used to acoustically match the subwoofer's output to your main speakers. Select the position, either 0° or 180°, in which your subwoofer has more output at the listening position.

(10) Sub Operation Switch

In LFE position, the Frequency adjustment becomes disabled and the subwoofer runs in a Full range mode, from 20Hz - 2kHz.

While in Sub position the subwoofer reverts to the manual frequency adjustment, allowing the user to operate and fine tune the subwoofer to their personal taste.

(11) 50Hz - 160Hz Frequency Adjustment

This controls the high frequency cutoff point. With the control set to the middle, the subwoofer will reproduce frequencies up to 105Hz. If the control is set fully clockwise, the crossover is bypassed and the subwoofer will reproduce a wide frequency range. With the control fully counter-clockwise the subwoofer reproduces a narrow range, up to 50Hz.

Rotate the control until the bass sound natural. If the mid-bass sounds natural but you want more low bass, turn the control down a little.

(12) Volume Control

Manual volume control to regulate your subwoofers power output, to prevent clipping and distortions caused by overpowering.



Always unplug the power cord before inspecting or changing the fuse. Never use a fuse with a larger current rating than recommended.

Installation

How to connect the ME-640 Plateamp

- Connect the red wire (marked as 1 in picture) to the positive (+) terminal on your subwoofer driver.
 - Connect the black wire (marked as 2 in the picture) to the negative (-) terminal on your subwoofer driver.
- NOTE: If your subwoofer doesn't support spade terminals, please remove them from the red and black wire.
- Install the ME-640 in the cutout hole of your subwoofer cabinet and make sure the screws have been tightened.

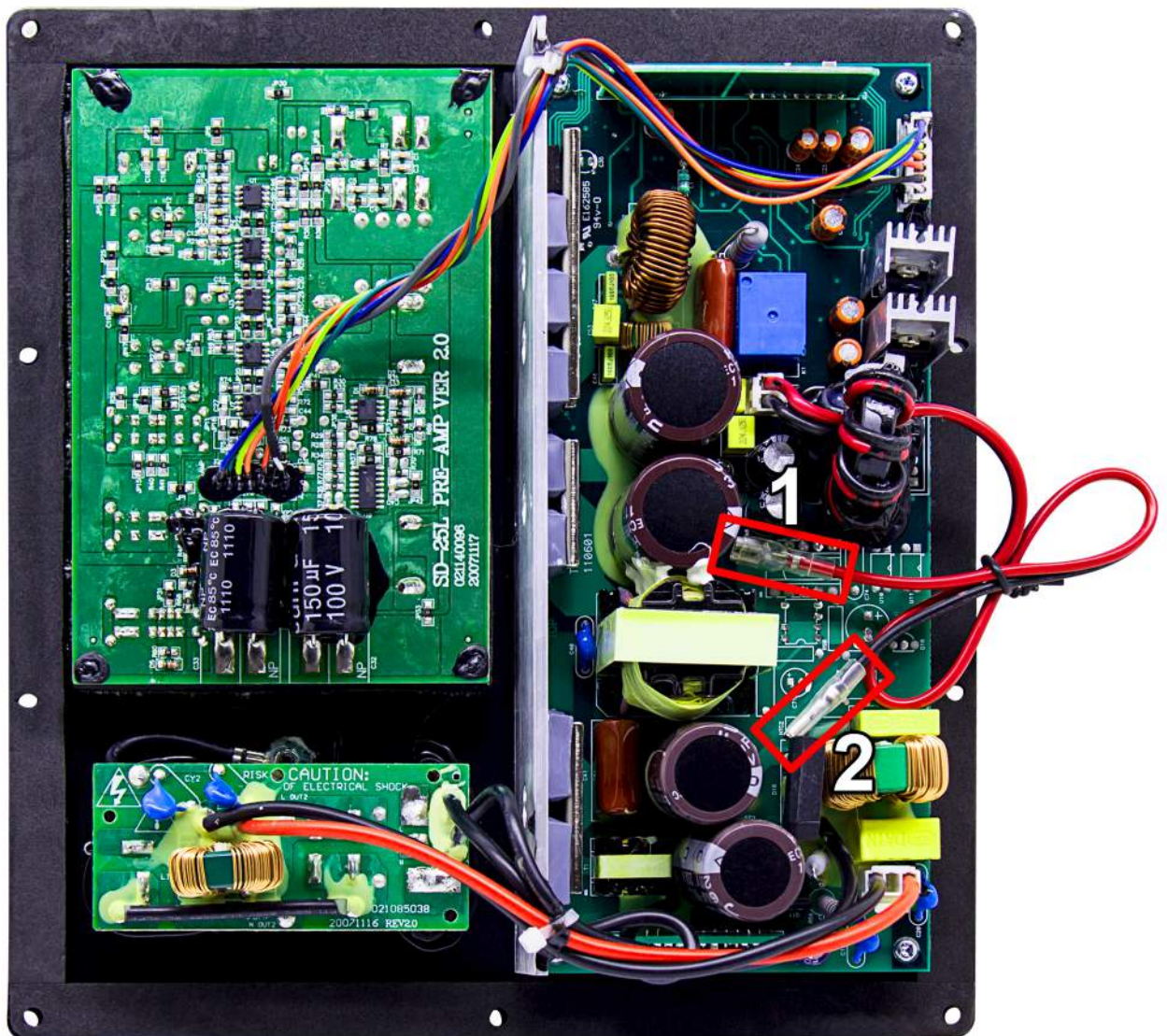

Installation

Observe the following general precautions and read the safety instructions before powering your subwoofer.

- Never open the cabinet or remove the metal control panel as this might result in an electrical shock to you, or damage to the unit.
- Protect it from prolonged exposure to direct sunlight and other direct sources of heat, such as heating vents and radiators.
- To prevent fire or shock, do not expose the unit to rain or moisture. If fluid or a foreign object should enter the unit, immediately turn off the power contact your Earthquake dealer.
- Avoid excessive exposure to extreme cold or dust.
- Do not place heavy objects on top of the unit.
- Do not place the subwoofer with its control panel against the floor.
- If you wish to place your woofer so the drivers face the floor and ceiling, thereby moving up and down, use at least 1-1 ½ inch high spikes or feet for support. They may be attached either with screws or self-stick backing . This arrangement will impart substantial house and floor shaking motion.

Heat Rise

- Allow adequate ventilation around the metal control panel of the subwoofer.

- Do not let anything come into contact with the panel and keep at least two inches away from any walls.

The metal control plate serves as the amplifier heat sink and also as a conduit to remove internal heat to the outside and into the atmosphere. It can reach temperatures of 60° C, which will feel hot to the touch, using nerves of flesh and blood as temperature sensors. As uncomfortable as it may feel, 60 degrees C cannot burn you, and in fact is almost cool to copper, silicon, steel, and aluminum the material from which your woofer is constructed.

AC Power Considerations

Ensure that the unit is plugged into an outlet capable of supplying the correct voltage specified for your model.

Unplug your subwoofer's power cord from the electrical outlet if it will be left unused for a long period of time.

Route the power-supply cord so it is not likely to be walked on or pinched by especially at plugs, convenience receptacles, and the point where it exits from the unit.

Magnetic Fields

We recommend that you place your woofer further than two feet away from your TV, VCR, DVD player, tape deck or computer, so the speaker's magnet won't distort the color of you TV picture or erase your video tapes, audio tapes, discs...etc.

Line Conditioner

DO NOT USE!

Connections

Please consider the following when setting up your new system:

- Before making or changing any connections, ALWAYS make sure that the subwoofer is unplugged from the wall and your other components are turned OFF. Also, turn down the volume control of the subwoofer and your pre-amplifier or receiver.

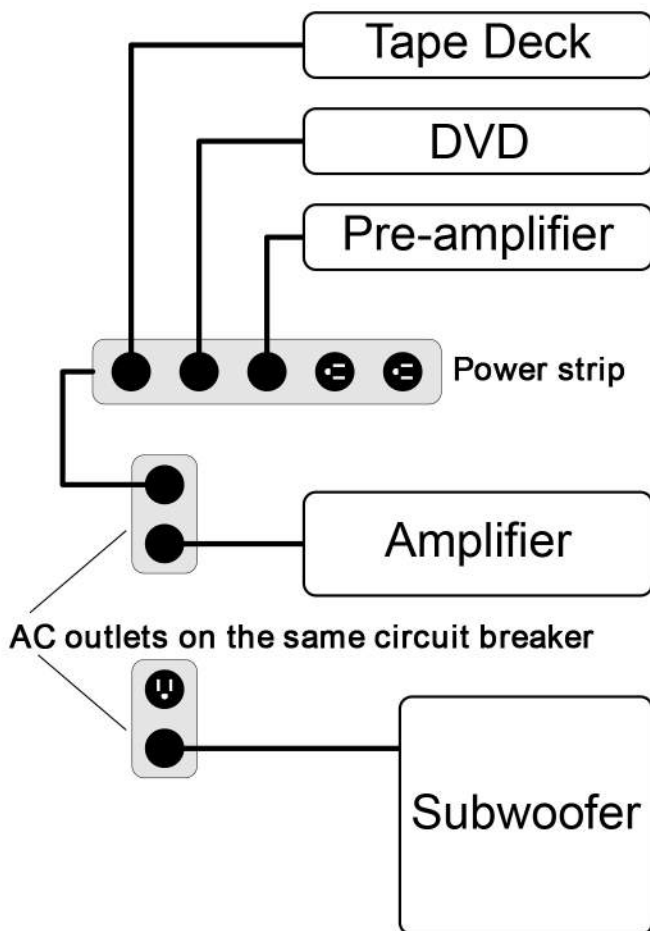

- This diagram shows all the low power components sharing a power strip which is connected to the same outlet used by the amplifier.

- The subwoofer is connected to an outlet on the same circuit breaker, provided that the total system current draw does not exceed the breaker current rating.

- This arrangement will reduce the possibility of an audible hum in your system caused by a ground loop.

- Whenever possible, keep the power cords away from the signal cable or speaker wires to prevent any hum or interference being heard in speakers.

- Choose reliable, high quality interconnect cables, also called patch cords or RCA cables. They should be fully shielded and as short as possible for the job. The longest cable in your system will likely be to the subwoofer, so choose a good quality brand.

- Some patch cords can be a very tight fit and there is usually a preferred method of getting them off. Some have to be removed with a twisting action. Be gentle or you may damage the jacks of the subwoofer or your other components.

Speaker Level Connections

- The subwoofer's Speaker Level Inputs can accept speaker stripped speaker wires only.

- Make sure that the negative speaker wires never touch the positive wires as this will short out and possibly damage your amplifier or receiver.

System Configurations

The following pages show some typical connections that you might make in your installation. They show how the inputs and outputs of the Earthquake sub are connected to your pre-amplifier or receiver.

Connections to a pre-amplifier's subwoofer output

If your pre-amplifier has a subwoofer output (often labeled LFE for Low Frequency Effects), it can be connected to the subwoofer's Left (Mono) input as shown. This is the simplest and recommended connection. A receiver with a sub/LFE output can be connected in the same way.

The subwoofer will play the low frequency range and the other speaker will play the frequency range delivered to them by your amplifier.

If you have a home theater pre-amplifier, it may have an independent subwoofer volume control. Make sure this is correctly adjusted, and that the Earthquake subwoofer's crossover frequency is set to 100Hz. This is by no means an iron-clad rule, rather it is a good starting point.

You can set the subwoofer's Bass Level control on your receiver to 0dB, and then use the pre-amplifier's subwoofer level control for normal and routine adjustments.

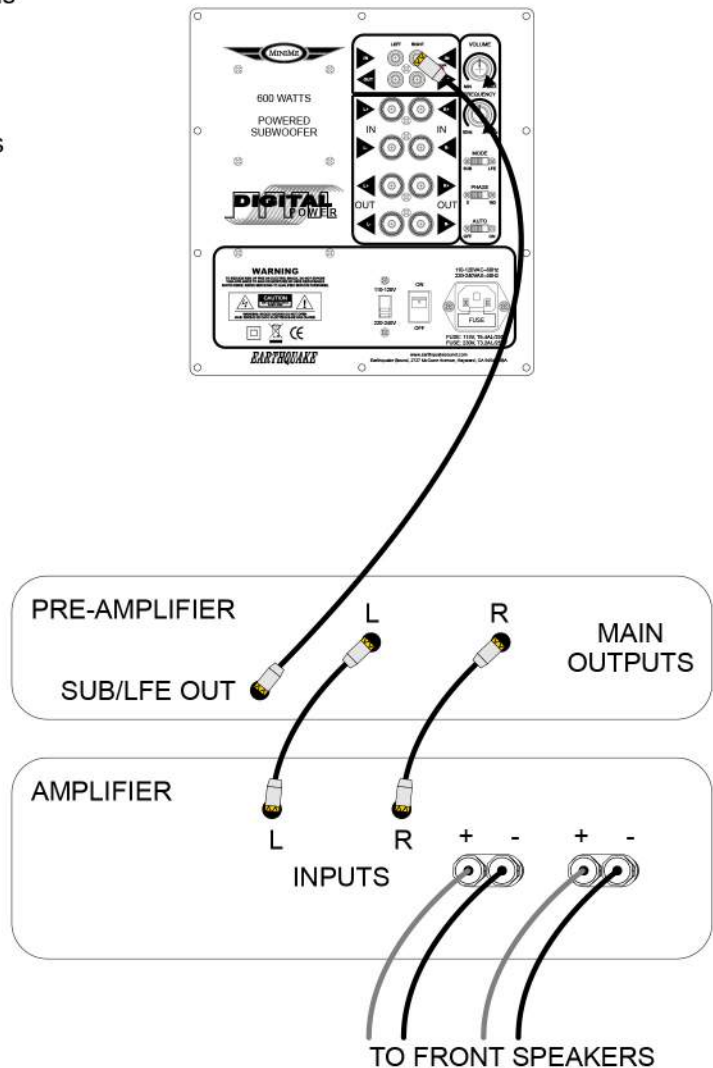

System Configurations

Connections to a pre-amplifier using “Y” cables

If your pre-amplifier does not have a sub/LFE output, you can use “Y” cables to send its main outputs to both the subwoofer and your amplifier.

The subwoofer will play the low frequency range and your front speakers will play the full range.

Although bass is commonly distributed evenly between left and right channels (L+R bass), movie soundtracks often contain differential (L-R) bass. The opening scene in “Top Gun”, for example, has loads of L-R bass information. If this is not preserved, the bass in these scenes sounds anemic. The Earthquake subwoofer utilized differential gain on the left and right inputs to retain both the L+R and L-R information. Therefore, systems which do not have a dedicated sub/LFE output should use both the left and the right inputs as shown, for the greatest bass impact.

An Alternative connection method without using “Y” cables is shown on the next page.

If your pre-amp/receiver has a dedicated sub/LFE output, the only the Left (Mono) input is used, as shown on the previous page.

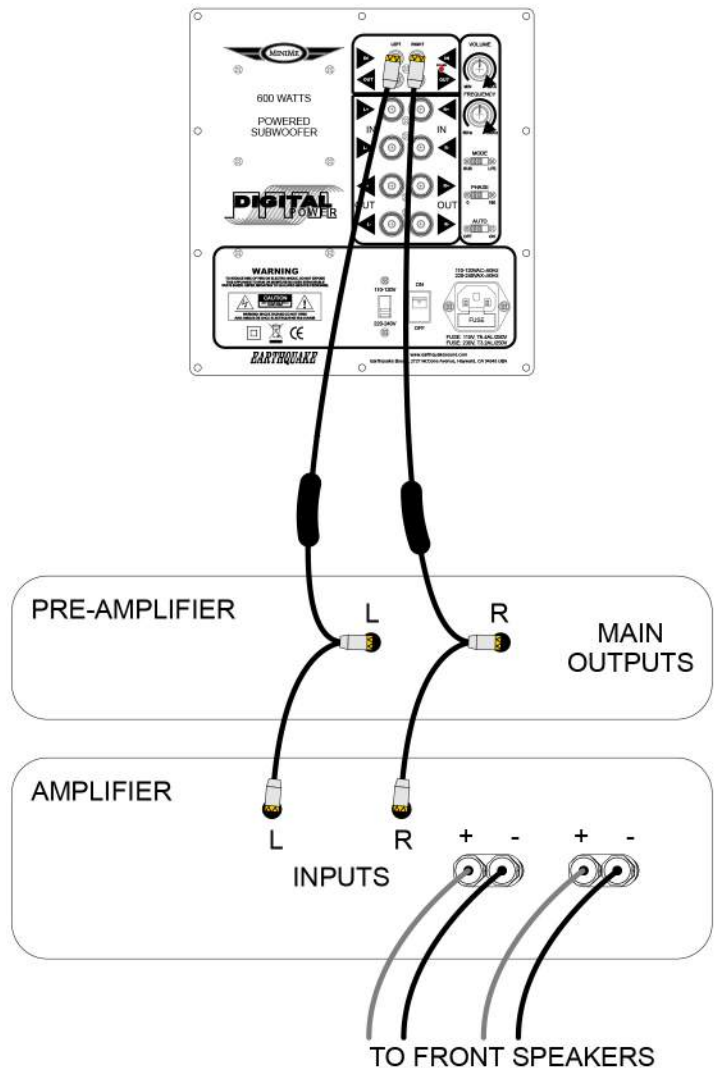

System Configurations

Using the line speaker-level inputs

If you are using a receiver which does not have a subwoofer output or line level outputs (pre-outs), you can connect its speaker outputs to the subwoofer's Speaker-Level inputs. The front speakers can still be connected to your receiver.

The subwoofer's internal amplifier supplies the power to reproduce the low frequency range. It receives a sample of the signal going to your front speakers. (An insignificant fraction of your receiver's power is transferred to the subwoofer).

There is no need to use the Speaker Level inputs if you are using a separate amplifier and pre-amplifier. Such systems are best connected using the Line Level Inputs as shown in the previous diagrams.

If you are using the Line Level inputs and there is an excessive amount of noise or hum present, using the Speaker Level inputs may yield a lower background noise level.

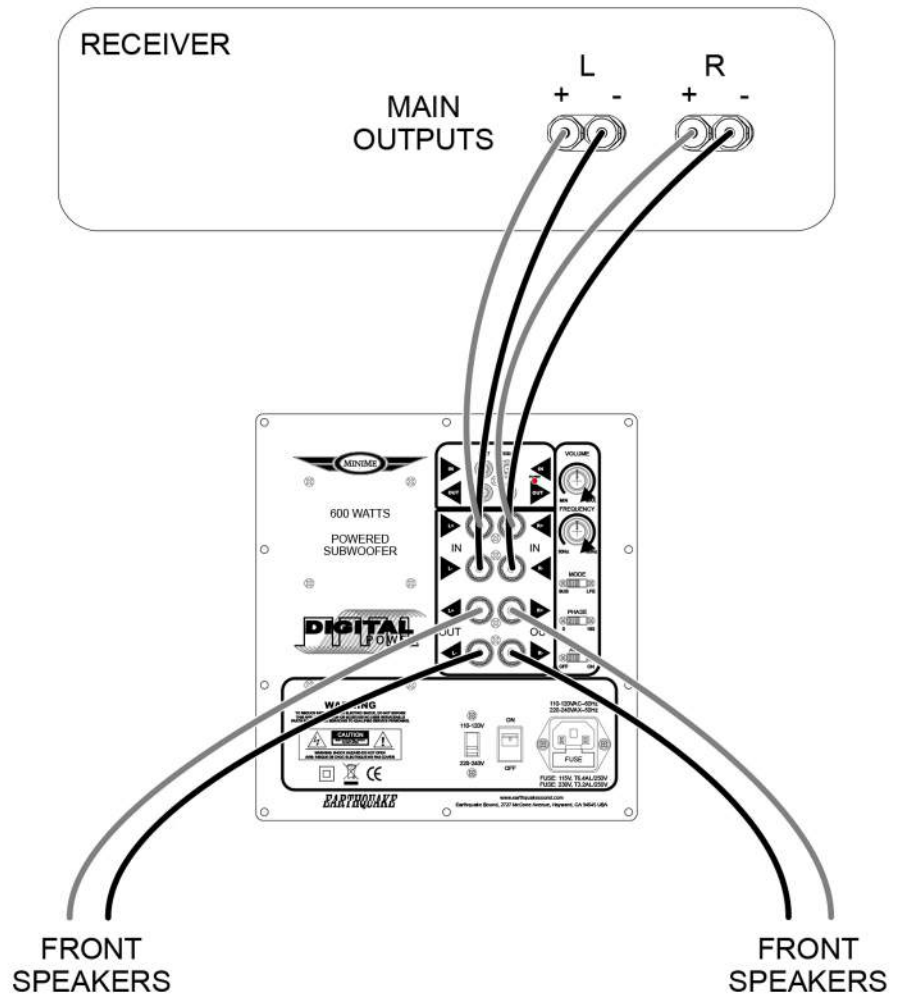

Adjusting the Controls

Adjusting the controls

There are two main methods for adjusting the level, crossover frequency and phase of the Earthquake MiniMe to match a system.

- ? Method One: Typical: Listening and making adjustments to suit your taste.
- ? Method Two: Laboratory: By measuring the output and adjusting for a flat frequency response.

Satisfactory results can be achieved if you make the adjustments based on simply listening. This is Earthquake's preferred method as it allows the system to be voiced based on what sounds the best, whereas laboratory-flat frequency response can often be clinical and less than exciting.

The following procedure is for those who prefer a more methodical and scientific approach.

You will need a test CD with low-frequency warble tones, and a sound pressure-level meter.

Step #1

Disconnect the subwoofer and run the main speaker with a tone in its passband (80-100Hz). Measure the level.

Step #2

Disconnect the main speaker and reconnect the subwoofer. Set the subwoofer to its highest crossover frequency. Set the level control of the subwoofer to give the same sound pressure level with the same tone you used in Step #1.

Step #3

With both the subwoofer and the main speaker connected, measure the level of the tones at the available frequencies. Because the crossover is set too high, you will have a peaked response. Adjust the crossover control to get the smoothest response.

Step #4

Use the phase control to make the response even smoother. It has its biggest effect at the crossover frequency. You can iterate between the crossover and the phases controls. Keep your hands off the level control! It was set correctly in Step #2.

Step #5

Listen to the subwoofer. Resist all temptation to turn up the level control. Play something with really deep bass to confirm that your subwoofer is working.

Control settings

Use the following charts to record more desirable data from test results.

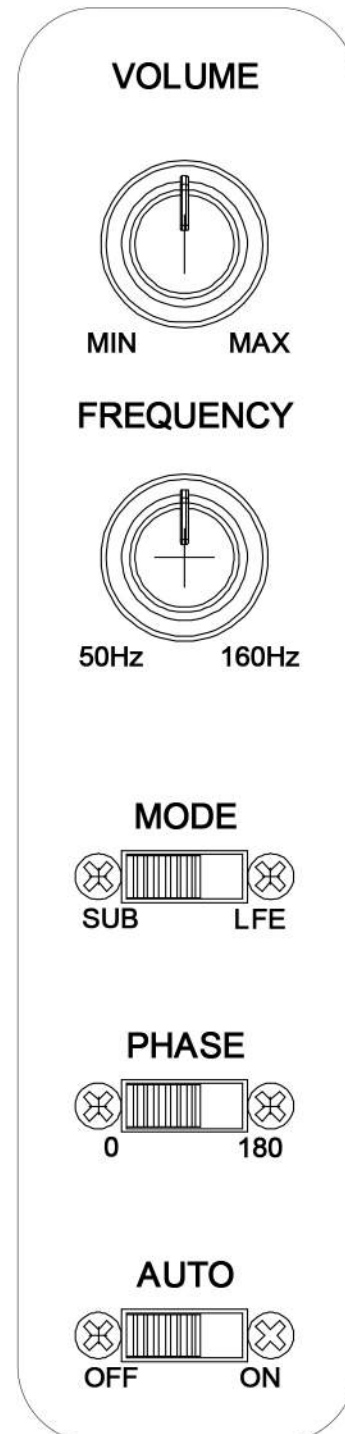

Specifications ME-640 Plateamp

Features

- Earthquake Evolved Class D Amplifier
- Standard room correction
- Airtight design for direct mounting in the subwoofer box
- 0-180 degree phase adjustment
- No reproduction below 10 Hz by modulator limitation
- Volume control
- RCA input and output
- Auto on/off
- Speaker power in and outputs

Specifications

- 640 Watts MAX at 230 volts pinknoise in 4 ohms
- 340 Watts MAX at 230 volts pinknoise in 8 ohms
- 600 Watts MAX at 115 volts pinknoise in 4 ohms
- 50 - 160 Hz frequency adjustment (24dB filter)

Outer dimensions

- Height: 240 mm
- Width: 225 mm
- Plate thickness: 3 mm
- Maximum insertion depth: 70 mm

Hole Size

- Height: 212 mm
- Width: 200 mm





Sound That Will Move You.

Earthquake Sound reserves the right to amend the details of the specifications without notice.
© Copyright Earthquake Sound Corporation.

Earthquake Europe • www.earthquakesound.eu • Mogensensvej 29 Dk-5000 Odense C
Office: +45 2043 8007 • support@earthquakesound.dk